



# Heat Sink Basics and DFM Guidelines for Customers

*Lunch ☺ 'n Learn☺ Notes*

Chris Sutton

Rev March 1, 2009



# Vette Summary



**Heat Sink Foundry**

**Vertically Integrated**

**7 China Facilities**

**1000 Employees**

**450,000 square feet**

**Heat Pipe Manufacturer**

**DC Fan Manufacturer**

**Extensive Customer Base**

**ISO, TUV, UL, Sony Green**

**Cisco PSL Supplier**

**500+ Cisco AVL Parts**

**Cisco Supplier >5 years**

**Global Support**

**US, Asia, Europe**

**Factory Dedicated Teams**

**Applications Engineer**

**CFD Analysis**

**Local Reps**



Welcome to the 16th Annual  
Supplier Appreciation Event

September 12, 2007



## Award Categories

John Groom Excellence in Quality  
Strengthening the quality link between  
Cisco and the end customer's experience

## Nomination Requirement

100% quality record for  
the last twelve months

Cisco has 750+ suppliers

## Nominees





# Factory Contacts



Chris Sutton – Sales Director

[csutton@vettecorp.com](mailto:csutton@vettecorp.com)

Cell: 949-661-3693

Azad Khodai – Cisco Account Manager

[azad@vettecorp.com](mailto:azad@vettecorp.com)

Cell: 650-644-5840

April Clark – Customer Service, Cisco

[aclark@vettecorp.com](mailto:aclark@vettecorp.com)

Off: 585-265-0550 x 207

Mark Pelillo – Applications Engineering

[mpelillo@vettecorp.com](mailto:mpelillo@vettecorp.com)

Cell: 214-697-2405

Mike Vega – Applications Engineer

[mvega@vettecorp.com](mailto:mvega@vettecorp.com)

Cell: 858-837-4559



# What to expect

NPI Orders – 3 to 4 weeks, working to get down to 2 weeks

Tooling Charges – typically \$400-\$800 depending on part size

Tooling Orders – 5 FAI and 30 Cpk parts

Quotes – 1 week for simple parts

Prototypes – 2 weeks for EDM parts

Thermal Analysis – 1 week or less, depends on workload

Drawings – 1 week or less

Production – 3 weeks typical

Pricing – monolithic pricing where possible

Continual Improvements



## Natural Convection

air movement with out an air mover (typically a fan), key factors are:

**Fin Surface Area**

more is better

**Fin Spacing**

fins must be spaced apart, low back pressure needed

**Fin Finish**

radiation can be up to 25% of the heat dissipation, surface emissivity of the finish is important, typically parts should be anodized.

**Fin Orientation**

fins must allow not prevent airflow

## Forced Convection

powered air flow, cooling is further enhanced by:

**Ducting**

keep the air flow in the heat sink, limit by-pass air

**Fin Orientation**

fins must not prevent air flow

**Fan Back Pressure**

design the heat sink that is optimized for airflow and pressure drop

**No Air Shadow**

do not block airflow in front or behind the heat sink

**More Air, More Air**

more air is good, more air is good, more air is good

**Parallel not Series**

heat sinks need to be placed in parallel not in series

**Go Wider**

wider heat sinks into more air are usually better than taller or longer



# Passive HS Construction

General  
Notes

## Stampings < 5W

Typical applications are TO-220's , parts stamped form sheet metal, low cost

## MicroForged <30W

High NRE and part cost

## Small Extrusions <30W

Board level such as BGA, Northbridge chip sets, DC/DC

**Straight Fin** used with known airflow direction

**Pin Fin** used with natural convection or unknown flow, or turbulent airflow

## Medium Extrusions <60W

lots of airflow

Heat sinks with maximum volume, fin area, large heat sources,

## Large Extrusions <200W

Very large components, IGBT's, SCR's, UPS

## Zipper Fin <150W

high fin density parts such a microprocessors

## Skived Fin <80W

alternate to Zipper fin, low NRE, higher cost, design limits

## Bonded Fin <200W

high fin density for large components, usually in power applications



# Active HS Construction

General  
Notes

**Fan Sink < 40W** Typical applications are old processors, fan mounted directly on heat sink

**Zipper Fan Sink <80W** Microprocessor applications

**Heat Pipe <140W** Microprocessor applications

**Straight Fin** used with known airflow direction

**Pin Fin** used with natural convection or unknown flow, or turbulent airflow

**Vapor Chamber <80W** heat sink with heat pipe type function but the base typically contains the working fluid, hardly used

**LCS (Liquid Cooling) <200W** High heat flux applications, expensive, typically 10X the cost of a heat pipe solution.

**Thermal Siphon <1000W** extreme power applications

**Peltiere Devices <80W** inefficient, limited cooling, expensive

**New Stuff <???** New ideas every day but not always cost efficient or practical



# Thermal Conductivities

General  
Notes

## Common Materials

W/m ° K.

Diamond	1,000	AL (pure)	225	Iron	76
Graphite*	500	AL 1100	218	Tin	63
Copper	385	AL 6063	209	Lead	33
Brass	120	AL 6061	167	Zinc	112
Nickel	61	AL 201(cast)	121	Air	<.03

## Thermal Interfaces

W/m ° K.

Tapes	xxx	Chomerics T411
PCM	0.73	Thermagon 105
Gap Fillers	11.0	FujiPoly 100Xe
Grease	>4.5	Shin Etsu G751
Graphite*	4	Furon C695
Epoxy	0.76	Loctite 384

TIM TESTING  
 ASTM E1530 ?  
 ASTM D5470 ?  
 ISO 8302 ?  
 PSI ??  
 PSI ??  
 PSI ??

TIM's are usually rated by thermal resistance, thickness, pressure and area

Aspect Ratio = Fin Height / Fin Gap = FH/FG

- < 7:1 No problem
- <10:1 Slower extrusion through put
- <15:1 Selected balanced shapes only
- <20:1 Consult factory
- >20:1 Very Select shapes only

[THE Heat Sink Alloy – Aluminum 6063-T5](#)

## Fin Features

.032" min thickness preferred for machining ease and speed, under .032" is a TFE (Thin Fin Extrusion)

.020" min thickness under most circumstances.

Tapered fins, preferred for strength, especially on thin fins parts.

Radii increase tool life, reduce part and tool stress

Serrated fins greatly increase tool back pressure, not recommended.

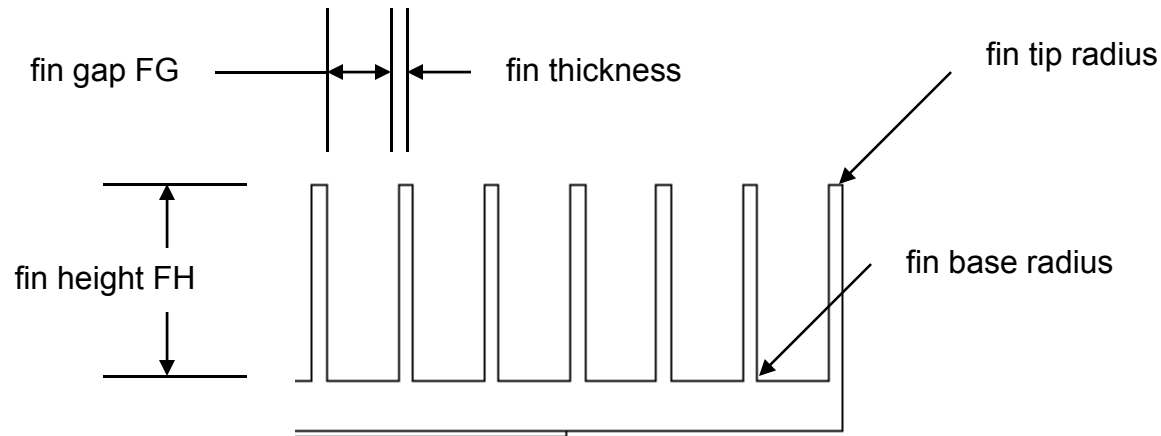

## Dimensional Tolerances for Aluminum Extrusions

VetteCorp's aluminum extrusion comply with the standard commercial tolerances established by The Aluminum Associations, INC. The tolerances for an extrusion dimension is a function of the die size of the particular dimension and the diameter of the extrusion die. Table B is a guide for most dimensional tolerances. The illustration shown is a typical flat back Extrusion. Tolerances for some extreme rations and some of the larger sizes tend to exceed the tolerances listed on this table and, conversely some of the smaller (less than 7 inch diagonal) can be supplied with half of the commercial Tolerances.

When defining machined flatness, use the statement of .001"/in. to preclude steps allowable with other methods of defining flatness. See Table A.

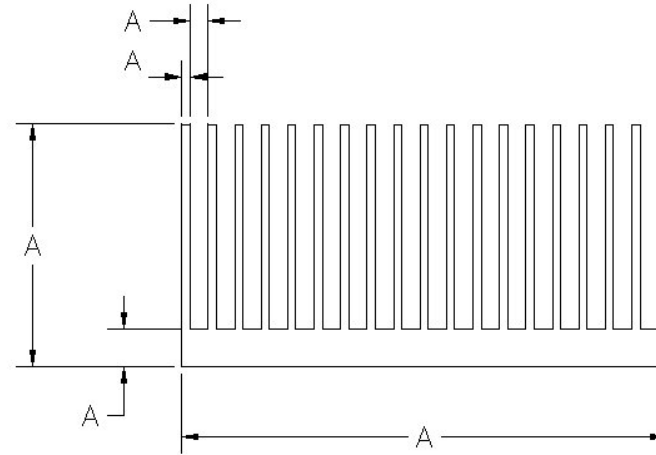

**TABLE A**  
**TYPICAL TOLERANCES FOR FLATNESS AND ROUGHNESS**

ALUMINUM SURFACE	FLATNESS [IN/IN] (mm/25.4mm)	SURFACE ROUGHNESS [RMS]
As Extruded	004 (0.10)	125-64 (3.2-1.6)
Sanding	.002-.003 (0.51-0.76)	64-32 (1.6-0.8)
Machined	.001 (.025)	64 - or better (1.6 -)

**TABLE B**  
**TYPICAL TOLERANCES FOR 6063-T5 EXTRUDED ALUMINUM ALLOY**

Dimension A (inches)/(mm)	+/- Tolerance (up to 10" circle size) (inches)/(mm)
0.000- 0.125 / 0.00-3.18	.006 / 0.15
0.125-0.249 / 3.18-6.35	.007 / 0.18
0.250-0.499 / 6.35-12.70	.008 / 0.20
0.500-0.749 / 12.70-19.05	.009 / 0.23
0.750-0.999 / 19.05-25.40	.010 / 0.25
1.000-1.499 / 25.40-38.10	.012 / 0.30
1.500-1.999 / 38.10-50.80	.014 / 0.35
2.000-3.999 / 50.80-101.60	.024 / 0.61
4.000-5.999 / 101.60-152.40	.034 / 0.86
6.000-7.999 / 152.40-203.20	.044 / 1.12
8.000-9.999 / 203.20-254.00	.054 / 1.37

## Base Spreading

When the heat source is smaller than the heat sink, the heat sink base thickness must be optimized to allow heat to flow through the base to the outer fins.

### THE Heat Sink Alloy – Aluminum 6063-T5

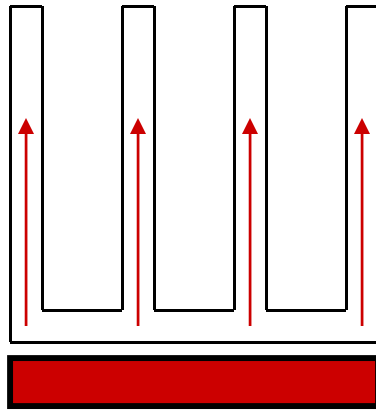

Heat Sink = Heat Source

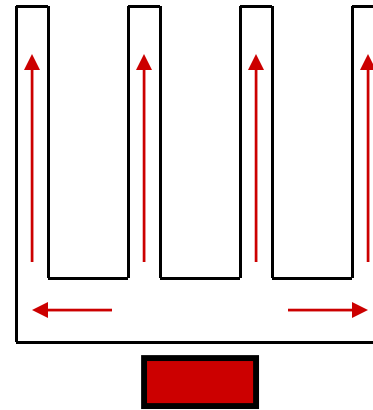

Heat Sink > Heat Source



# Fin Notes

General  
Notes

## Straight Fin

Best thermal performance, lowest cost, low back pressure, airflow to be in the fin direction

## Pin Fin

Good performance, higher back pressure, best for unknown / turbulent / natural convection airflows

## Round Pin Fin

Usually on die cast or microforged parts, usually more costly and lower performing

## Elliptical / Tapered Fin

Good for very low back pressure, high NRE, high part cost. Microforged parts can have very thin fins.

## Too Many Fins

High back pressure, air may not flow through the parts.

## Natural Convection

Fins must be widely spaced, ex .200 inch or heat will radiate from one fin to the next.

## Cross Cuts

Break the static air flow boundary later

Flatness = \$\$\$ Specify the flatness that you need but only where you need it  
Cisco Standard is .002"/" in the heat source area

**TABLE 5 Flatness (Flat Surfaces)①—Bar, Solid Profiles and Semihollow Profiles**

EXCEPT FOR PROFILES IN O®, T3510, T4510, T6510, T73510, T76510 and T8510 TEMPER®

MINIMUM THICKNESS OF METAL FORMING THE SURFACE in.	SURFACE WIDTH—in.										
	UP TO 5.999	6.000 TO 7.999	8.000 TO 9.999	10.000 TO 11.999	12.000 TO 13.999	14.000 TO 15.999	16.000 TO 17.999	18.000 TO 19.999	20.000 TO 21.999	22.000 TO 23.999	24.000 AND UP
	TOLERANCE										
Up thru .0124	.004	.006	.010	.014	..	..	.014	..	..	..	..
0.125-0.187	.004	.006	.008	.012	.014	.014	.014	..	..	..	..
0.188-0.249	.004	.006	.008	.010	.012	.012	.012	.014	.014	..	..
0.250-0.374	.004	.006	.006	.008	.010	.010	.012	.012	.012	.014	..
0.375-0.499	.004	.004	.006	.008	.008	.008	.010	.010	.010	.012	.014
0.500-0.749	.004	.004	.006	.006	.008	.008	.008	.008	.010	.010	.012
0.750-0.999	.004	.004	.006	.006	.008	.008	.008	.008	.008	.008	.010
1.000-1.499	.004	.004	.004	.006	.006	.008	.008	.008	.008	.008	.008
1.500-1.999	.004	.004	.004	.004	.006	.006	.006	.008	.008	.008	.008
2.000 and up	.004	.004	.004	.004	.004	.006	.006	.006	.008	.008	.008

For all numbered footnotes, see page 27.

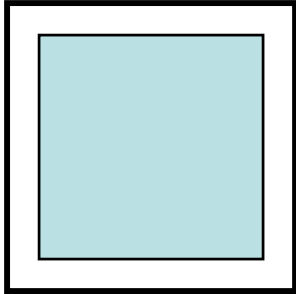

Single flatness callout is fine  
Small parts will probably be  $< .002''$  as extruded

Flatness = \$\$\$

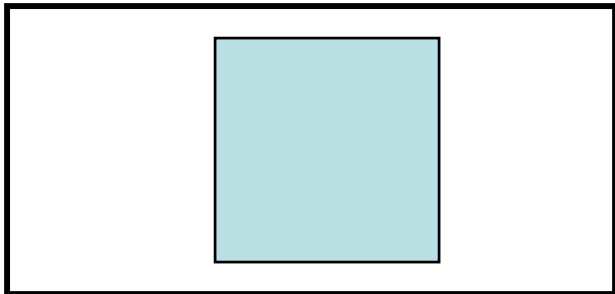

Specify flatness in heat source area  
Go with standard callout on the rest of the part

Flatness = \$\$\$



Specify flatness in source areas  
Do they need to be related ??  
Standard callout on the rest of the part

Flatness = \$\$\$

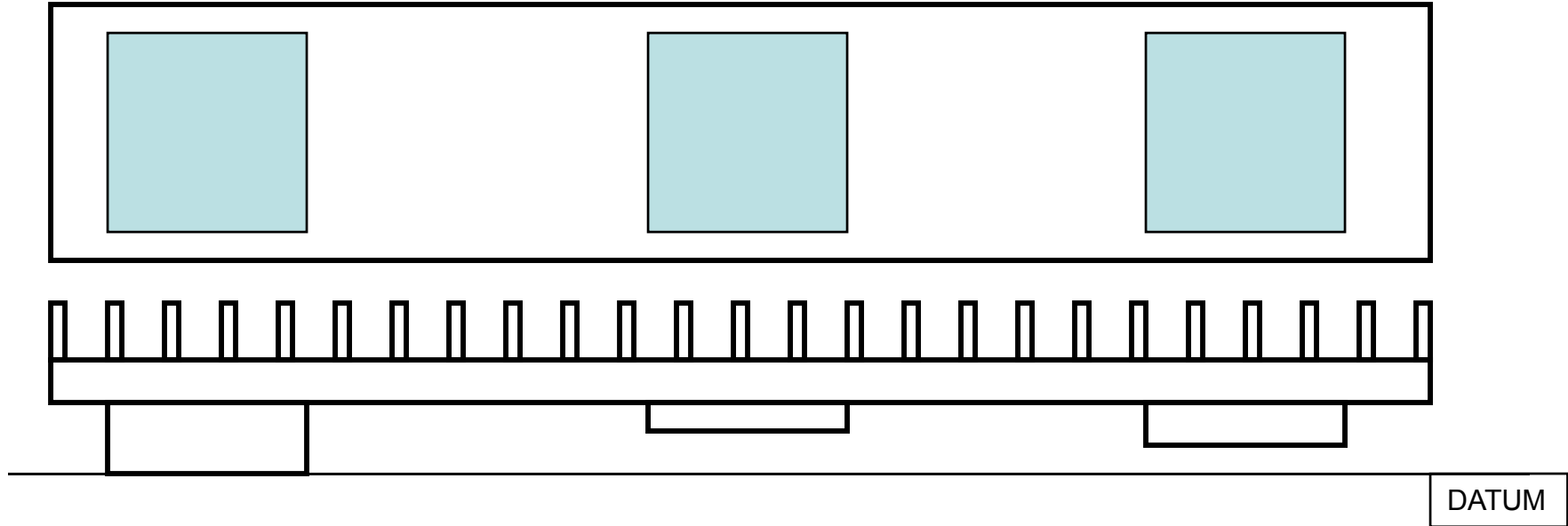

1. Parts are CNC machined from the bottom.
2. Datum the lowest machined pedestal surface NOT the base of the heat sink.
3. Will the center heat source always contact the heat sink ??
4. Gap filler TIMs (.020"+) are expensive.
5. Machined standoffs have the same dimensioning problems.
6. We machine it flat but when we open the vise, the part may spring back.
7. Thin base parts flex, how do we measure a part with flex ??

Magnified Sketch of the Interface between Heat Source and Heat Sink

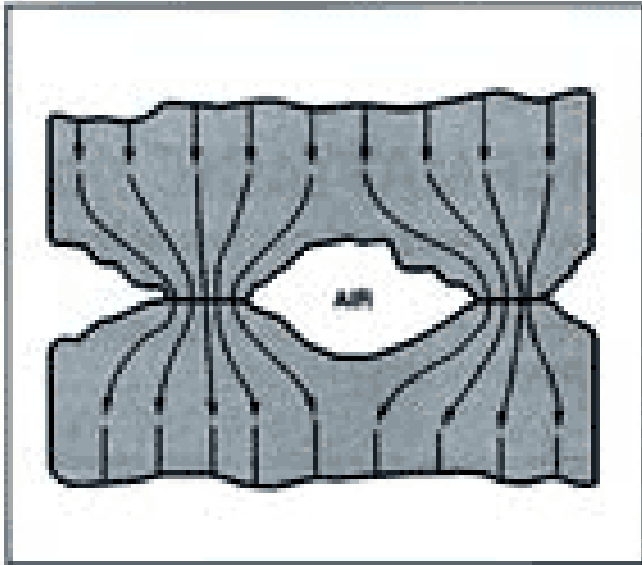

Poor Heat Transfer

Small heat conduction area  
and insulating air pockets

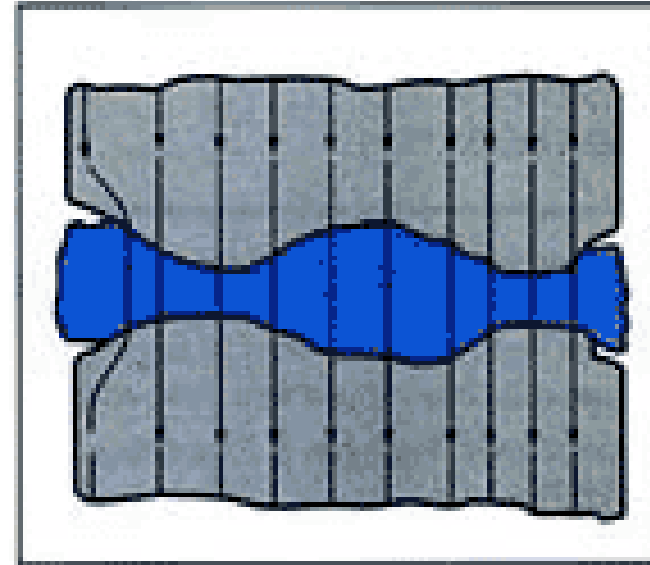

Good Heat Transfer

Larger heat conduction  
area and no air pockets  
(PCM example)



# Thermal Interface Types

General  
Notes

**Double Sided PSA** Pressure Sensitive Adhesive used to adhere heat sink to the heat source, heat sink and heat source are should be with 50%. Easy to assemble, pull tabs available on most materials. Need to select a specific tape for mounting surface i.e. metal, plastic, ceramic, silicon, etc. Typically .005-.010" thick

**Single Sided PSA** provides interface adhered to the heat sink only. Mechanical fastening of the heat sink is needed i.e. push pins, wire clips, band clips, screws, plastic clip, etc. Typically .005-.010" thick

**SSA** Single Sided Adhesive, alternate terminology.

**Graphite** commonly used on DC/DC converters, usually .005" and .010" thick.

**PCM** Phase Change Material, higher performance TIM that reflows with heat to fill all the interface voids, difficult to apply, usually supplied with a pull tab/release liner . Typically .002-.004" thick.

**Gap Filler** typically .020" and thicker pad with some compressability, used to fill varying gap sizes, mechanical fastening is required.

**Epoxy** thermally loaded filler adhesive system, provides permanent and strong mechanical attachment, often not favored by assemblers due to the possible prep work and inability to rework.

**Grease** excellent thermals, void filling capability and very thin interface, mechanical attachment required, but can be messy and is not favored by assemblers. Can be silk screened on by the factory but parts need covers to prevent dust and dirt contamination. Typically .001"-.002" thick

**Pull Tabs** release liner feature which makes assembly much easier, not available on all TIMs

**Urethane Gaskets** commonly used on small heat source flip chip parts to reduce chip breakage

## Tolerance Summary

Item	Feature	Units	Tolerance	Notes
1	TIM Pad Size (length or width)	mm	±0.25	1
2	TIM Pad Position (edge-to-edge)	mm	±0.50	1
3	TIM Grease Size (length or width)	mm	±0.50	1
4	TIM Grease Location (edge-to-edge)	mm	±0.50	1

Notes:

1. Tolerance reflects material state at point of manufacture.
2. Conversion: 1.0" = 25.4mm

## Feature Diagram

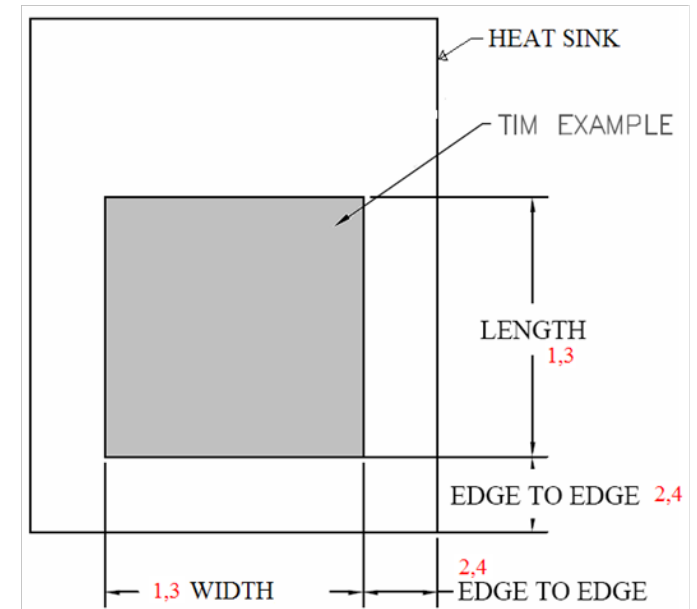



# Heat sink Attachment

General  
Notes

**Double Sided PSA** Pressure Sensitive Adhesive used to adhere heat sink to the heat source.

## Push Pins

**Plastic** low cost, 0-3 lbs per pin, low cost, use Nylon 66, requires holes in PCB.

**Brass** for heavier parts to meet drop test, 4x times cost of a plastic pin.

**Wire Clips** low cost, 0-6 lbs, needs PCB anchors (solder or omega pin).

**Band Clips** high force, high cost, high NRE.

**Screws/Springs** good solution on custom parts, requires inserts in PCB

**Plastic Clips** no board space required but high NRE and no flexibility

## Materials and Tolerances

### Springs

- ✓ Music Wire
- ✓ Stainless Steel

### Tolerances

- ✓ **Free Length  $\pm 0.050''$  (1.27mm)**
- ✓ Wire Diameter  $\pm 0.002''$  (.05mm)
- ✓ Spring Rate  $\pm 15\%$  of stated value

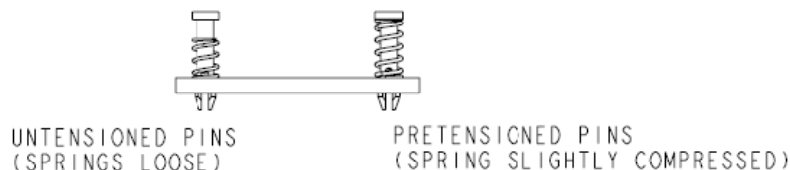

**Design Criteria:**  
Pins should always be pre-tensioned

## Determining spring length:

- Deflection 4mm, desired force 9N
- Heat sink base 3mm  $\pm .25$ mm
- Choose a pin length so that the pin head is level to or below heat sink height after installation. Working length= 14mm  $\pm .2$ mm
- Using a plastic Pin calculate required spring rate: force/deflection = 2.25N/mm
- Do a tolerance study to determine best/worst case free length

$$\text{Working length} + \text{tol} - \text{heatsink} - \text{tol} = \text{XXmm}$$

$$\text{Working length} - \text{tol} - \text{heatsink} + \text{tol} = \text{XXmm}$$

Refer to standard spring catalogs ([www.leespring.com](http://www.leespring.com)/[www.asraymond.com](http://www.asraymond.com)) to find next **longest** spring with **closest** spring rate. In this case C0180-022-0500M or LC-022-5-M.

# Push Pin Design

## Materials and Recommended Forces

### Pins

- ✚ Plastic (Nylon based) Forces 0-3lbs (0-13.5 N)
- ✚ Metal (Brass) Forces 0-5 lbs (0 – 22N)

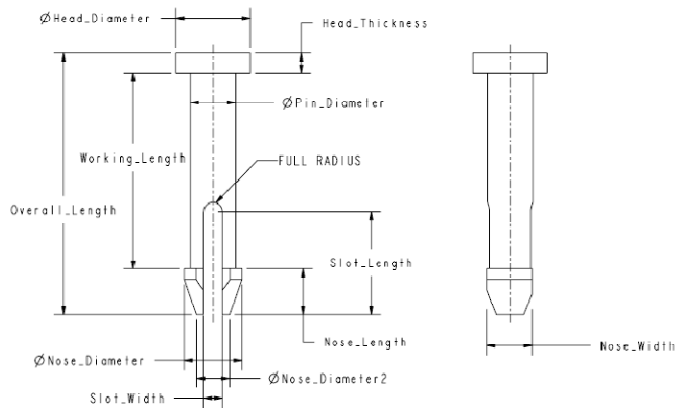

### Metal Pin Definition and Tolerances

- Head Diameter should be equal to or greater than the spring outer diameter
- Pin Diameter should be less than the spring inner diameter
- Nose Length should be at least .080”(2mm), the longer the better
- Nose Diameter should be .140”(3.56mm) for PCB holes of .118”(3.0mm) to .125”(3.2mm)
- Nose Diameter2 should be about .04”(1mm) smaller than PCB hole size
- Slot Width should be sized to allow Nose Diameter to fit into the PCB hole
- Slot Length should be determined via mechanical analysis to determine yield stress of the pin
- Nose Width should be equal to Pin Diameter
- Tolerances: all tolerances typically  $\pm .005$ ”(.13mm)

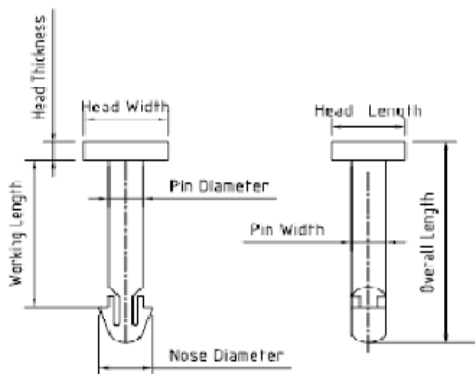

### Plastic Pin Definition and Tolerances

- Head Width/Head Length should be equal to or greater than the spring outer diameter
- Pin Diameter should be less than the spring inner diameter
- Nose Diameter should be .140”(3.56mm) for PCB holes of .118”(3.0mm) to .125”(3.2mm)
- Nose Width should be equal to Pin Diameter
- Tolerances: all tolerances typically  $\pm .008$ ”(.20mm)

## Tolerance Summary

Item	Feature	Units	Tolerance	Notes
1	Wire Dia	mm	$\pm 0.05$	-
2	J Hook	mm	$\pm 0.30$	-
3	Total Span	mm	$\pm 0.30$	-
4	Clip Jogs	mm	$\pm 0.30$	-
5	Step Length	mm	$\pm 0.25$	1
6	Leg Form	mm	$\pm 0.50$	2
7	Assembly to heat sink	mm	$\pm 0.50$	-
8	Bend Angle	°	$\pm 3.0$	-

### Notes:

1. Tolerance is of straight section only, radii not included
2. Tolerance does include radii
3. Conversion: 1.0" = 25.4mm

## Feature Diagram

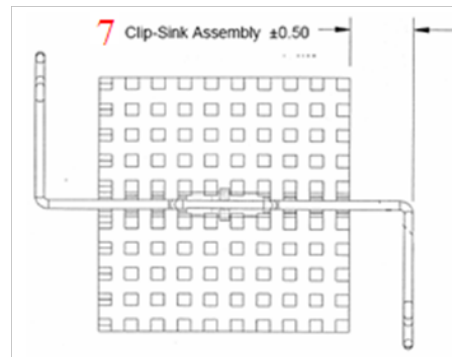
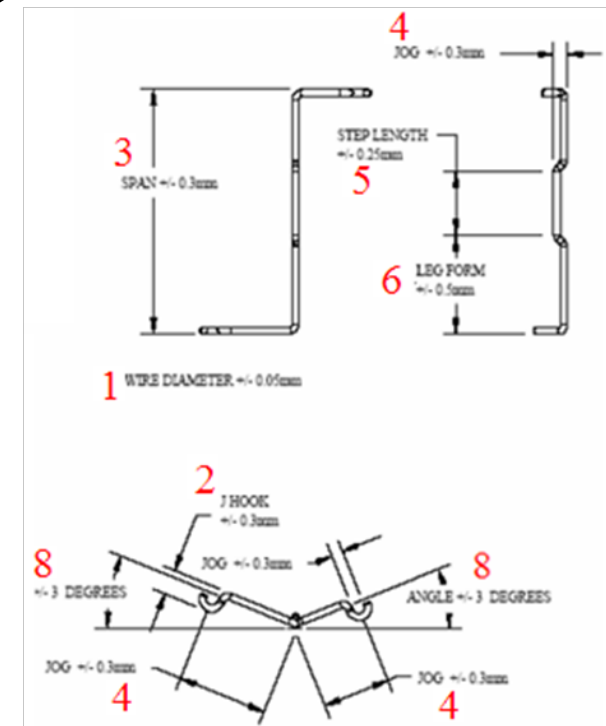

## Tolerance Summary

Item	Feature	Units	Tolerance		Notes
			Precision	Economy	
1	Hole Location: Ctr-to-Ctr	mm	±0.15	±0.30	-
2	Hole Location: Edge-to-Ctr	mm	±0.25	±0.30	-
3	Hole Size (Ø)	mm	±0.10	±0.15	1, 2
4	Hole Depth (Blind)	mm	±0.30	±0.50	-
5	Surface Flatness	mm/mm	0.002	0.005	1, 2
6	Surface Roughness/Finish	RMS, µm	0.8~1.6	1.6~3.2	2
7	Square Cut-out	mm	±0.15	±0.40	-
8	Cut to Length	mm	±0.25	±0.38	-
9	Base Thickness	mm	±0.15	±0.25	3

Notes:

1. Process tolerance may vary with material type & temper.
2. Process capability will vary with thickness
3. Bases thickness over 12.7mm may have increased associated tolerance
4. Conversion: 1.0" = 25.4mm

## Feature Diagram

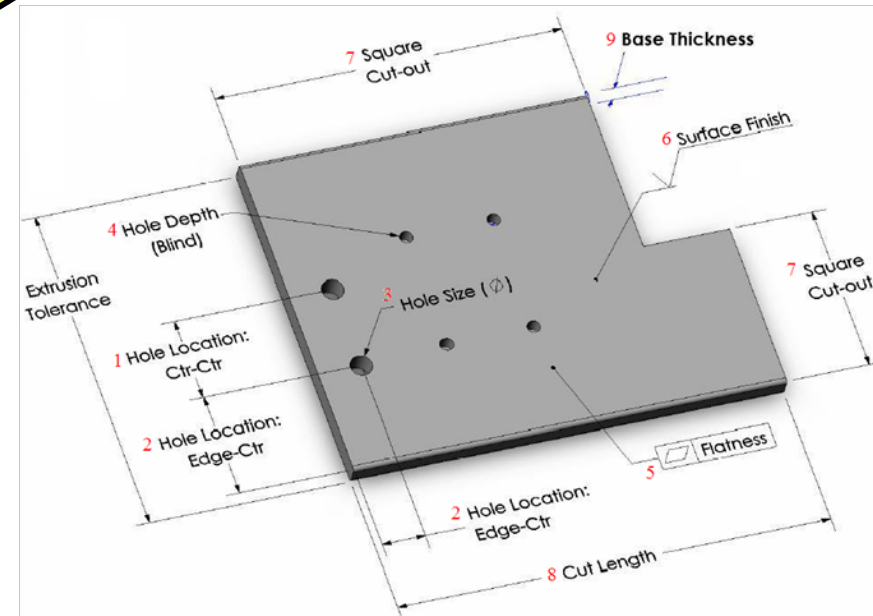

## Tolerance Summary

Item	Feature	Units	Tolerance	Notes
1	Pin Fin Thickness	mm	$\pm 0.25$	1, 2
2	Cross-cut Channel	mm	$\pm 0.25$	1, 2

Notes:

1. Tolerances valid for fin heights < 50mm
2. Tolerance valid for Cross-cut channels > 1.5mm
3. Conversion: 1.0" = 25.4mm

## Feature Diagram

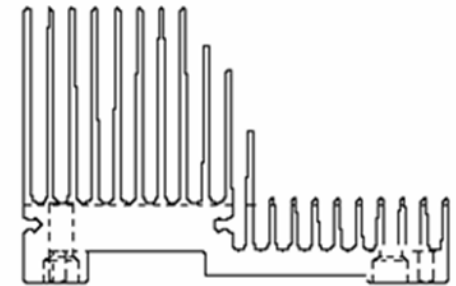
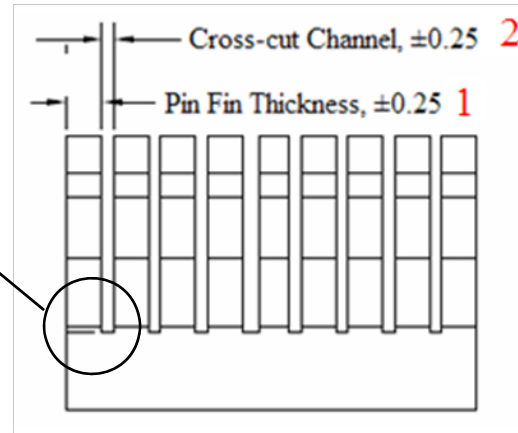
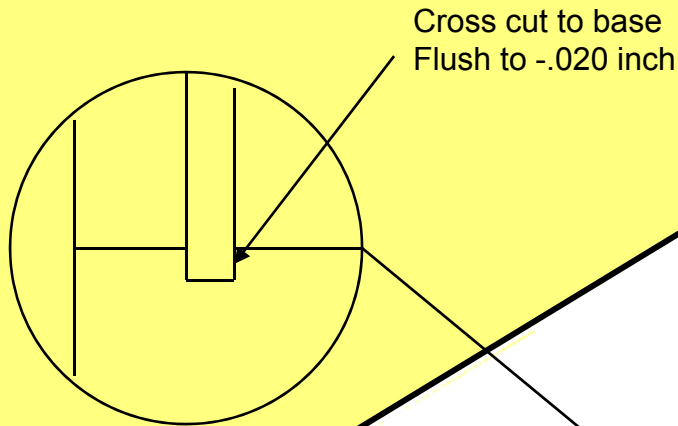



# Finishes

## Anodizing

Aluminum oxide finish, excellent emissivity (important for natural convection), tough finish, low cost, electrically non-conductive, colors are dyed in and do not effect emissivity, black and clear are standard, several automatic lines. RoHS compliant.

## Chromate aka Chemfilm, Irridite, Aludyne

Dip type finish that seals the pores in the metal, low cost, available in clear and yellow, electrically conductive, can be rubbed off.

**Hexavalent Chromate, Cr-6** is non RoHS compliant, do not use

**Trivalent Chromate, Cr-3** is RoHS compliant, use this. Clear only.

**McDermitt Process**, non Chromate Chromate, available.

**Mill** aka plain, wash, bare, wash and debur

**Nickel** solderable, may be needed depending on HS construction, good for tough environments

## Tolerance Summary

Item	Feature	Units	Tolerance	Notes
1	Extruded Hole (Ø)	mm	±0.13	1
2	Non-Hole, Feature-to-Feature Location	mm	±0.20	1
3	Hole-to-Hole Location	mm	±0.10	1
4	Hole Size (Ø)	mm	±0.10	1
5	Feature Dimension (non-hole)	mm	±0.25	1
6	Solder Assembly (base edge-to-fin)	mm	±0.50	1
7	Fin Material Thickness	mm	±0.025	1
8	Assembled Fin Pack Width (stack)	mm	±0.50	1
9	Stamped Fin Length (height or length)	mm	±0.25	1
10	Distance between formed features	mm	±0.25	1

Notes:

1. Tolerances valid for base material < 1.0mm
2. Conversion: 1.0" = 25.4mm

## Feature Diagram

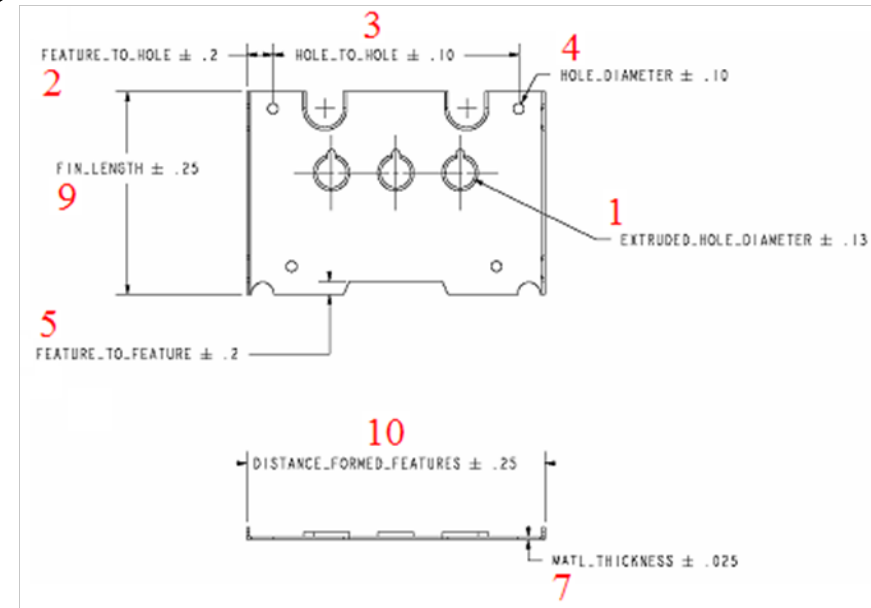

**Heat pipes do not dissipate heat  
they move it to another location**

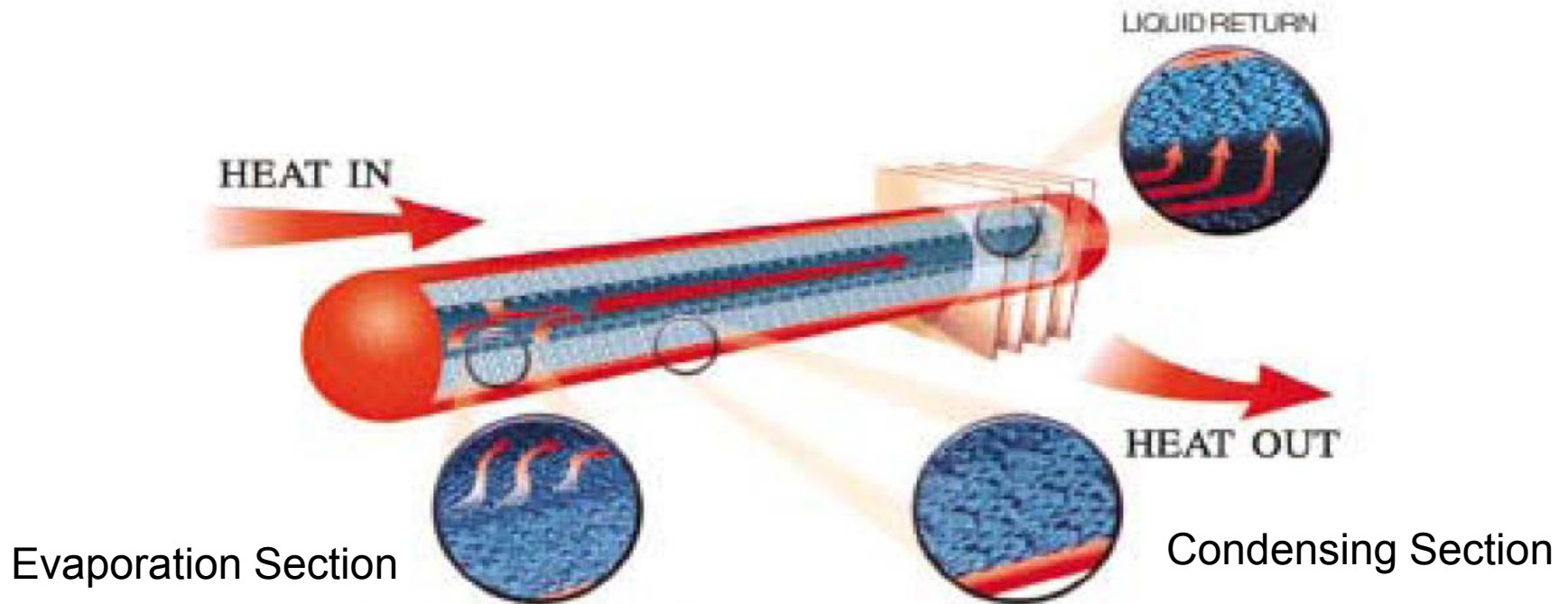



# Heat Pipe Construction

General  
Notes

**Sintered Copper** best performance, sintered copper balls wicking mechanism, best for formed heat pipe shapes (bending and flattening), low internal back pressure as core area is wide open, wicking action 360 degrees around inside of the heat pipe.

**Copper Powder** alternate name for sintered copper.

**Grooved** low cost, part has internal grooves for wicking action but grooves are distorted when pipes are bent or formed, limiting wicking action. Suitable for straight pipe solutions.

---

**Wick** low cost, part has a lamp type wick inside

**Fiber** type of wick construction,

Wicking action ?

**Spring** coil spring inside copper housing.

Internal back pressure ?

**Mesh** low cost, part has a wire mesh inside.

**Hybrid** combination, such as grooved and wire mesh to improve wicking action.

## Tolerance Summary

Item	Feature	Units	Tolerance	Notes
1	Length (end of Pipe-to-bend)	mm	±0.50	-
2	Length (Bend-to-crimp)	mm	±1.00	-
3	Diameter of Pipe	mm	±0.13	-
4	Bend Angle	°	±3.0	-
5	Flattened Pipe (thickness)	mm	±0.15	-
6	Flattened Pipe (width)	mm	±0.15	-
7	Flatten Surface	mm	±1.00	-
8	Inside bend radius (minimum)		2 X Ø	-

Notes:

1. Conversion: 1.0" = 25.4mm

## Feature Diagram

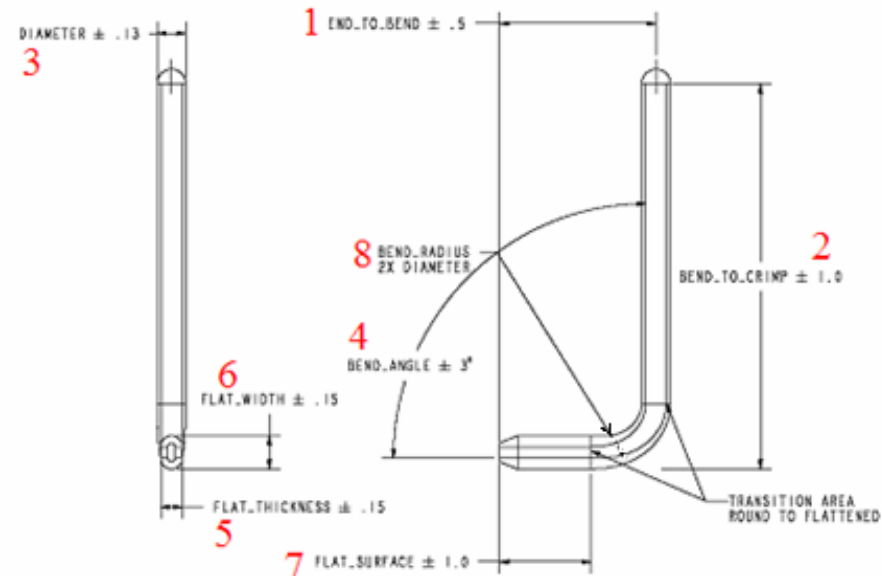



# Materials & Treatments

Standard  
Materials  
& Finish

Sheet & Extrusion Alloys	Thickness & Diameter	RoHS Surface Treatments
<p><b>Aluminum</b></p> <p>Sheet &amp; Coil: 1050, 1100 or 5052</p> <p>Extrusion: 6063-T5</p> <p>Cast Alloy: ADC10, ADC12</p>	<p><b>Sheet &amp; Plate</b></p> <p>Thickness up to 1.0mm 0.2, 0.3, 0.5, 0.6, 0.8, 1.0</p> <p>Thickness 1.0 ~ 5.0mm 1.5, 2.0, 2.5, 3.0, 3.5, 4.0, 4.5, 5.0</p>	<p><b>Anodizing</b></p> <p>Standard Colors: Black &amp; Clear Available: Blue, Green, Red, Gold</p>
<p><b>Copper</b></p> <p>Sheet &amp; Extrusion: C1100</p>	<p><b>Wire</b></p> <p>Diameters up to 1.0mm 0.2, 0.3, 0.4, 0.5, 0.8, 1.0</p> <p>Diameters 1.0 ~ 3.0mm 1.0, 1.5, 2.0, 2.5, 3.0</p>	<p><b>Trivalent Chromate</b></p> <p>Color: Clear (OK for ROHS)</p> <p><b>Other Treatments</b></p> <ul style="list-style-type: none"> <li>•Bare aka Wash aka Plain</li> <li>•Electroless Nickel</li> <li>•Copper Passivation (Anti-oxidant)</li> </ul>
<p><b>Stainless Steel</b></p> <p>Sheet</p> <ul style="list-style-type: none"> <li>•SK-7 (heat treatable, S410)</li> <li>•301</li> </ul>		<p><b>Finishes</b></p> <ul style="list-style-type: none"> <li>•Mill Finish aka “as extruded”</li> <li>•Bead Blast</li> <li>•Grain aka Sanded</li> <li>•Polish aka Mirror Finish</li> </ul>